



**Ranger – 3D Camera:
Fastest 3D Available!**

Measure it all at once at unsurpassed speed

Ranger: Fastest 3D available!

Measure it all at once at unsurpassed speed

What Ranger can do for you

Ranger is the ultimate camera for the most advanced needs. With its unsurpassed 3D measurement speed, high flexibility, and MultiScan functionality, it serves as the key vision component for 3D scanner manufacturers and vision integrators. With the use of laser triangulation, the Ranger extracts the true shape of objects which can be used to measure object height, shape and volume, to detect and locate shape defects, or to make quality grading. In addition to measuring 3D, the Ranger can also measure a multitude of other object features such as gray scale, gloss, and scatter – at the very same time. Hence, with the use of one single camera, several different aspects of an object can be collected to reach even more robust results for decision making.

Ranger is offered in several different versions suitable for most needs. In the high-performance segment, speeds of up to 35 000 3D-profiles per second can be reached and grayscale data resolution in MultiScan mode of up to 3 072 pixels is possible. For the price sensitive applications, cameras with pure 3D functionality with speeds of up to 1 000 profiles are offered.

Ranger offers full flexibility and by a selection of the appropriate lens and external light sources, it can be optimized for applications in the whole range from the small-sized electronic component inspection to the large-scale log inspection. By a unique calibration concept, a Ranger system can easily be set up to deliver accurate 3D data in millimeters or inches.

Ranger sends the measurement data to a hosting PC via a high-speed communication interface; variants for both CameraLink and Gigabit Ethernet are available. Application development is made in a C or C++ programming environment or with the use of 3rd party image analysis software.

Benefits with Ranger:

- The fastest 3D camera available
- MultiScan – Measure several object features at the same time
- Flexible solution for a wide range of applications
- Accurate 3D measurements in millimeters
- Data from several Rangers can be combined
- Free choice of image analysis routines
- Standard communication interfaces
- Best market price/performance

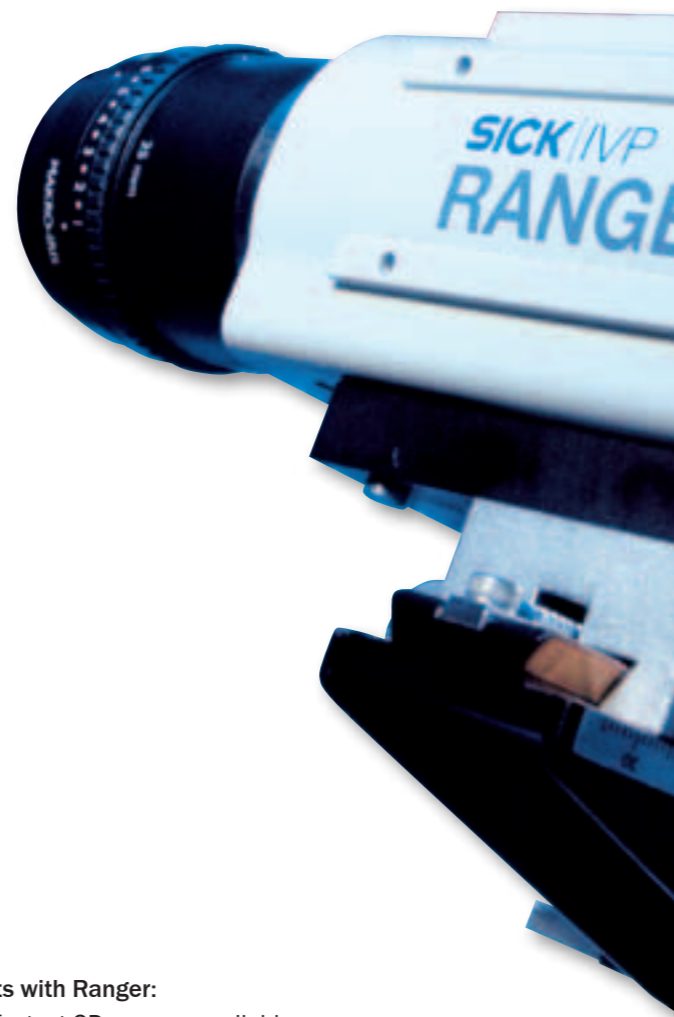

Applications

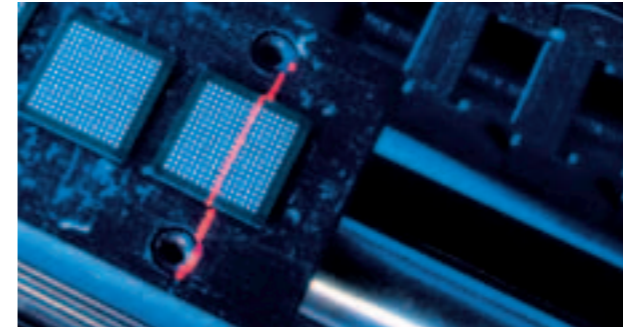
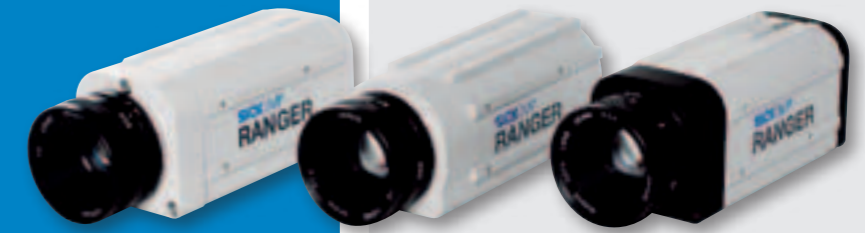

Ranger for 3D dimension control

3D data from Ranger can be used to measure the size and shape of objects in a wide range of applications, from large-scale applications down to detecting the finest details in the electronic assembly industry. In this application the Ranger is used in a component scanner to verify that the height of each ball of the BGA is correct with micrometer resolution.



Ranger for contrast-independent inspection

In many applications the contrast between the object feature to measure and its surrounding is not suitable for 2D imaging. It can be too low, as in this tyre inspection, or with too much variations as with some printed matters. With Ranger, the 3D measurements are nearly contrast independent. For the tyre inspection application this is vital in order to detect surface errors, or to analyse the relief identification code on the side of the tyre.



Ranger for MultiScan quality grading

In grading applications it is very common that both shape and surface properties of objects need to be evaluated (such as gloss, intensity, and scatter). In the board grading application, Ranger data is used to both measure the shape of the board and to detect defects such as knots, small cracks, and pitch pockets. In such applications, the boards are traversed at very high speed and hence high-speed measurements are essential.



Ranger for production quality control

Quality control before the final packaging is especially important in the pharmaceutical industry. It is essential that each blister cell contains one undamaged pill. With ordinary gray scale imaging, the pills cannot be seen nor can the cell shape be measured. With the MultiScan capabilities of the Ranger, the shape of each cell can be verified, the surface and print code analysed, and the presence of pills beneath the semi-transparent covering plastic can be verified.

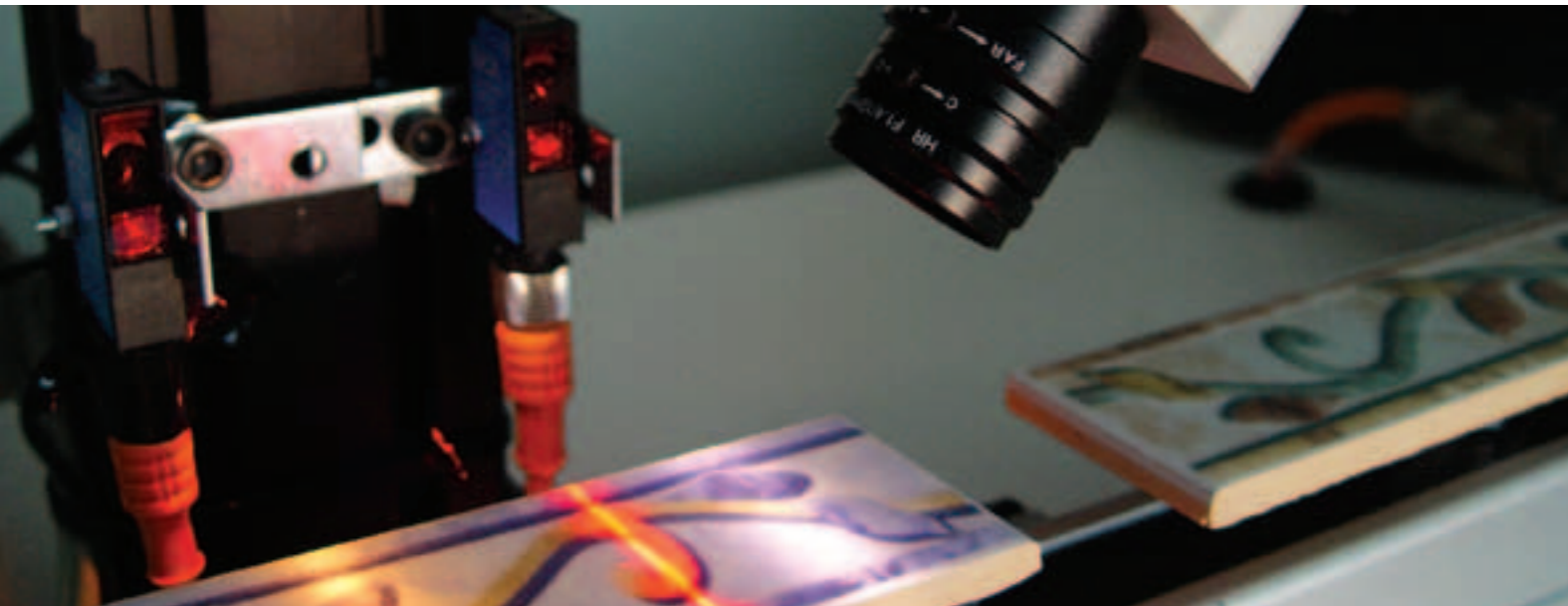

Ranger – the technology

The imaging in Ranger is based on a unique patented CMOS-sensor optimized for calculation of 3D coordinates and at the same time measuring other object features with a line scan approach. The field-of-view and the resolution are adapted to each specific need by selecting the appropriate optics and illumination sources. The profile capture rate and data quality is adjusted by software parameters and can be optimized for each application.

Ranger has a solid metal housing and industrial connectors. It has been designed for robustness in order to fulfill the tough requirements from our OEM customers and vision integrators, and will stand vibrations and accelerated movements that are common in industrial applications. Many of these customers use the Ranger as their key vision component in their 3D scanners.

The Ranger family consists of three main models which differ in performance and communication interfaces. Each model is moreover available in versions with different sensor resolutions and optional IR-pass filter.

Features:

- 3D and MultiScan at highest speed
- Contrast-independent 3D measurements
- Up to 1 536 individual measurements in a 3D profile
- Up to 3 072 pixels in gray scale measurements
- Patented technology for laser scatter measurements
- Free choice of field-of-view
- Easy 3D Calibration assistance
- Ambient light robustness with IR option
- Adjustable resolution and measurement range
- High flexibility with parameter-controlled measurements
- PC software for configuration and data visualization
- C++ and C APIs for application development
- Standard communication interfaces:
 - CameraLink or Gigabit Ethernet
- Industrial cables and connectors

Ranger models

Ranger C

Ranger C is a high-speed 3D and MultiScan camera with CameraLink interface for speeds of up to 30 000 profiles/s in 3D mode. It has several 3D algorithms and MultiScan components. The Ranger C is highly configurable via software parameters. It has I/O at TTL level for trigger, encoder and external light synchronization.

There are five different versions of Ranger C available: C40, C50, C55 and C50/C55 with IR filter (see technical specifications at the end of this brochure).

Ranger E

Ranger E is a high-speed 3D and MultiScan camera with Gigabit Ethernet interface for speeds of up to 35 000 profiles/s in 3D mode. It has several 3D algorithms and MultiScan components. The Ranger E is highly configurable via software parameters. It has 24 V I/O for trigger and camera control, differential RS422 for encoder inputs (5 V level), and TTL output for external light synchronization.

There are five different versions of Ranger E available: E40, E50, E55, and E50/E55 with IR filter (see technical specifications at the end of this brochure).

Ranger D

Ranger D is a mid-speed 3D camera with Gigabit Ethernet interface for speeds of up to 1 000 profiles/s. It uses a high precision 3D algorithm with few software parameters. It does not support the MultiScan functionality. It has 24 V I/O for trigger and camera control, differential RS422 for encoder inputs (5 V level), and TTL output for external light synchronization.

There are two different versions of Ranger D available: D40 and D50 (see technical specifications at the end of this brochure).



Getting 3D data

Ranger measures 3D data according to the laser triangulation principle. Hence, to be able to measure 3D shape, an external line-generating laser source is required. The laser module is mounted to project its laser line on to the object. The camera, that views the line from a different angle, sees a curve that follows the height profile of the object. By measuring the laser line deviations from a straight imaginary reference line, the height of the object can be computed. As the object moves through the laser beam, contour slices of the object are generated. The collection of such slices, or 3D profiles, is a description of the complete object shape as seen from the upper side of the object. The unique camera technology is capable of finding the position of the laser line by itself and reducing to whole image information into compact laser coordinates. It is only these laser coordinates that are transmitted to the PC. This makes 3D imaging with Ranger very fast and reliable.

Ranger offers several different methods for the generation of 3D profiles which differs in speed and height resolution. The different algorithms have different strengths making them more suitable for certain inspection scenarios. This flexibility of the Ranger can be used to optimize results for each specific inspection task.

Height resolution and calibrated data

The height resolution of the 3D measurements from the Ranger is dependent on the angle between the laser and the camera. As this angle is increased, the height resolution is also increased but at the expense of a decrease of the total height range. As a consequence of this freedom to tune the height resolution, the Ranger cannot be factory calibrated but instead delivers 3D measurements in sensor coordinates (pixels).

In applications where the actual shape, size, or position, of objects needs to be measured, it is essential to have calibrated measurements in for instance millimeters. Calibration is a matter of translating what the camera sees in sensor coordinates (pixels) to world coordinates (e.g. millimeters or inches). This includes compensating for lens distortion, perspective, and laser-camera angle.

Ranger comes with a complete calibration concept that is suitable for in-machine calibration and adaptable to the size of the field-of-view (FOV). The calibration procedure does not rely on stable movement nor accurate positioning but is performed by holding a calibration target by hand at random positions in the FOV. A software tool (Coordinator) assists during the complete calibration procedure which can be completed in a few minutes. This makes the calibration very easy and keeps the integration costs to a minimum. After calibration, the Ranger is ready to deliver 3D data in e.g. millimeters.

The MultiScan functionality

In addition to measuring 3D, Ranger E and Ranger C are capable of measuring several other object properties at the very same time. This camera functionality is referred to as MultiScan. By adding appropriate light sources, several aspects of information about the object such as gloss, surface reflection, absorption in different wavelengths, and laser scatter, can be measured. By combining these object features, very powerful and reliable object analysis applications can be developed, solving the most challenging inspection tasks. Moreover, since only one Ranger camera unit is needed for this, the solution and maintenance costs can be kept low.

All measurements in MultiScan mode, apart from 3D data, are acquired in a line scan manner. Each measurement, also referred to as component, uses its own part of the sensor where the external light source is measured. The parameters to control integration time etc. can be set independently of other components. The resulting data is then transmitted to individual buffers in the PC. The unique sensor in combination with the flexible configuration possibilities allows for up to ten different properties to be measured in parallel. The MultiScan configuration is set up via camera software parameters described in readable XML.

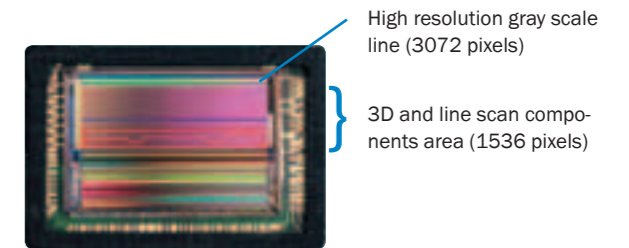

In MultiScan, different parts of the sensor are assigned to different image components by software configuration. Any component combination is possible.

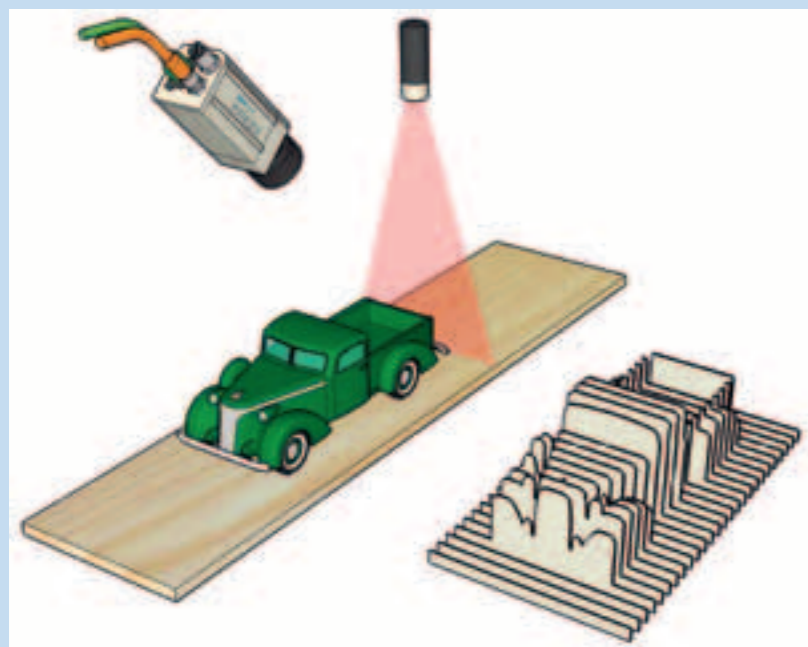
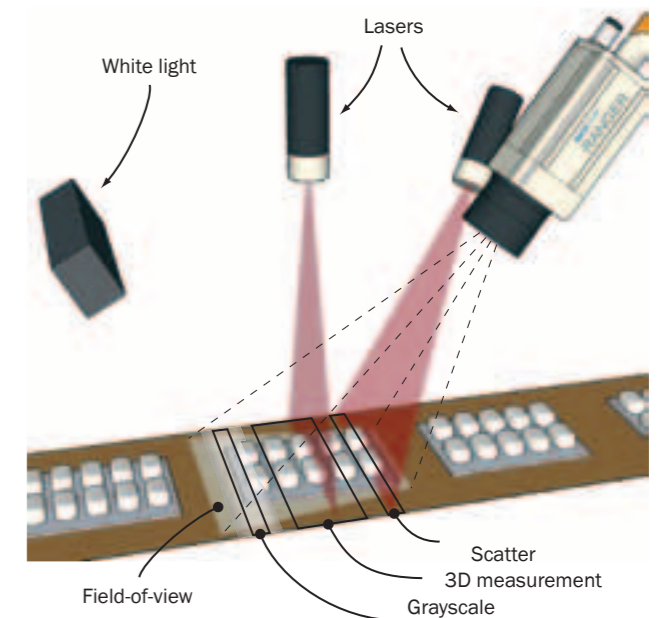

As the object moves through the laser beam, contour slices are generated that together form the complete object shape.

3D image with height information in gray scale where brighter values correspond to higher height positions.

3D-rendered visualization of the same object as above. Different colours indicate different height levels.

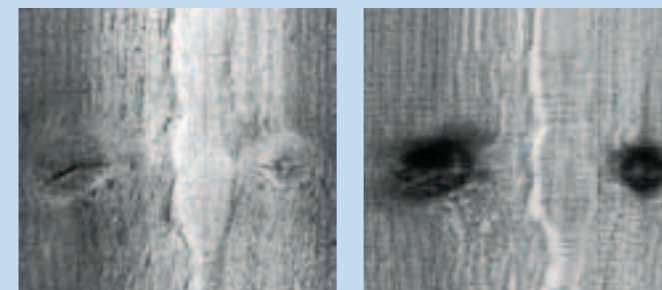
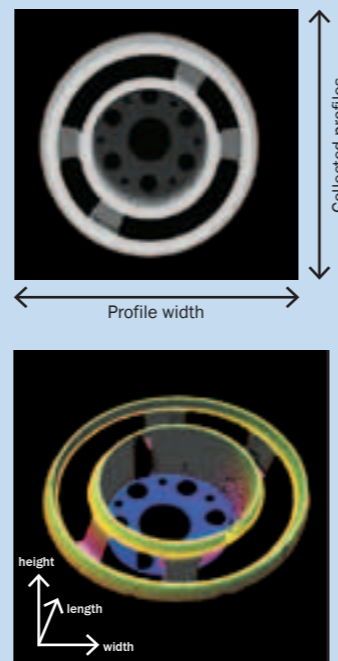

The intensity image of a board to the left and the scatter image (Tracheid) to the right. Note how the knots in the scatter image appear much darker than in the intensity image, thus making the knot identification much easier and more robust.

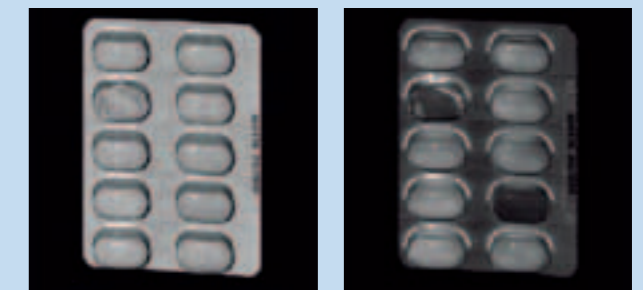

The intensity image of a blister pack to the left and the scatter image to the right. Note how two cells of the blister pack are much darker in the scatter image. This indicates that pills are missing in these cells, something which is not possible to conclude from the intensity image.

High Speed 3D

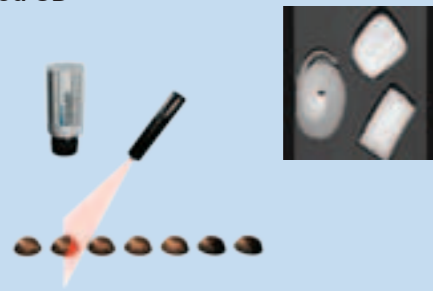

High Resolution Grayscale

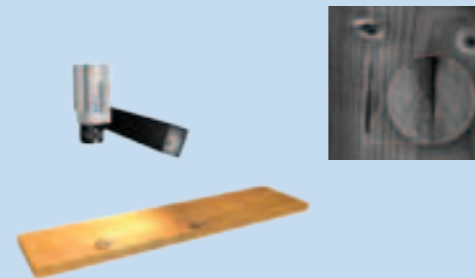

Gloss Measurement



Laser Scatter



There are four basic MultiScan components available, including the 3D component. The scatter component provides a measurement on how the laser light spreads, or scatters, just beneath the surface of the object. As an example, the scatter measurement is commonly used in the wood industry for robust detection of knots and defects. It can also be used to inspect what is beneath a semi-transparent layer (see image examples on the previous page). The scatter measurement is a patented technology by SICK.

The gray scale component can be used to reveal several different aspects of the objects. As an example, by setting up a directional white light source in a steep angle, surface gloss can be measured and used to reveal surface defects like scratches. For the Ranger E55 and C55 models, there is furthermore a component to measure high resolution gray scale of up to 3 072 pixels resolution. Such highly resolved data becomes very useful for the inspection of fine details and the detection of tiny defects.

Complete shape and surface analysis

In order to measure the complete object shape and surface, data from several sides of the object needs to be collected. In such cases, data from several Rangers mounted around the object (e.g. above and below the object) can be combined. For a multiple Ranger E or D system, a Gigabit Ethernet switch can be used to gather the measurement data into one single cable for the connection to the hosting PC.

Movement synchronization

The data stream of profiles can be synchronized with the object movement or conveyor speed using an external encoder. This functionality will ensure that the length measurement and object scale in the movement direction is correct, even if the object speed varies or if a backward movement should occur. Moreover, an external light switch or similar can be connected to the Ranger in order to acquire data only when an object is within the measurement region.

Application development

Having the Ranger as the data streaming component in a PC environment, very flexible and powerful solutions can be developed since both the performance of the PC and the selected image processing algorithms can be precisely selected. There are several third party software packages available on the market that can be used with Ranger to develop complete inspection solutions.

Ranger is incorporated into software applications for Windows XP using one of the two APIs included on the 3D Camera development software: iCon C++ for use with Visual Studio and iCon C for use with most common C-compilers.

Ranger as an application component

The figure below describes an application where the Ranger is the vision component in an inspection system where the quality and content of blister packs need to be assured.

The Ranger serves as the MultiScan data source, providing the hosting PC with 3D profiles, surface gray scale, and laser scatter information. These three different measurements are all required to solve the inspection task: find shape-damaged cells, verify the printed text, and detect any empty cells. An encoder is used to synchronize the data stream with the actual movement to get correct object size. A light switch is used to detect the beginning of the blister pack.

As soon as data is being collected, or if preferred, when the whole object has been scanned, the PC software application starts to analyze the MultiScan data. The software application uses its own image processing library to analyze the 3D shape, verify date code and detect missing pills using the scatter data in order to identify faulty items. The result is then transmitted to the controlling unit, in this case a PLC, which will use the input to reject any faulty blister packs.

Ranger as the vision component in an application for inspection of blister packs. Packs with missing pills, damaged cells, or faulty date code should be rejected.

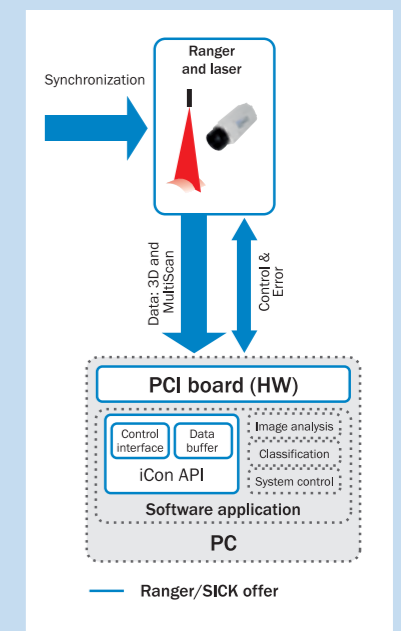
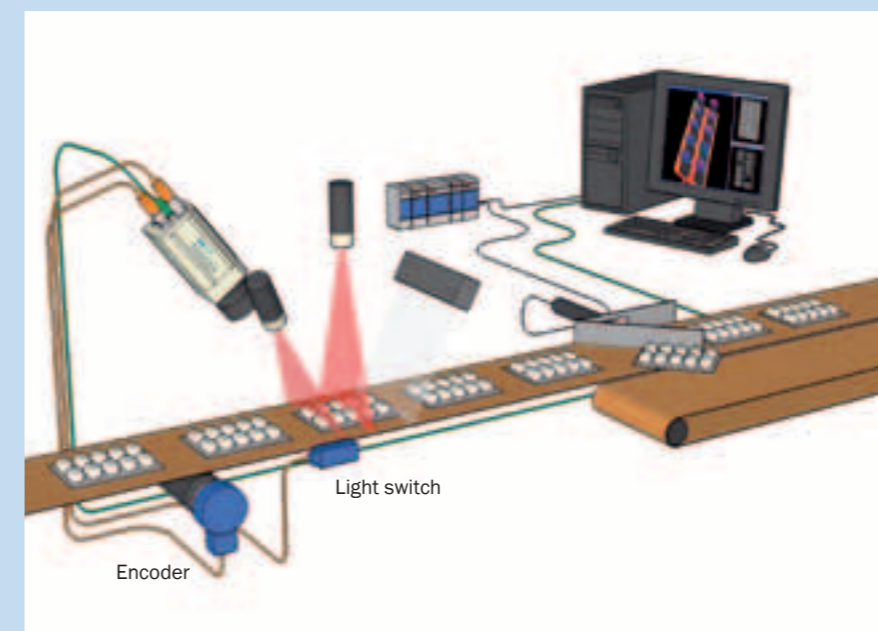

Ranger Studio

Ranger Studio is a graphical user interface for evaluation of the Ranger and its possibilities. It can be used to configure the camera and to visualize the collected data. It hence serves as a valuable tool to understand how to work with Ranger, to get acquainted with all the possibilities that the Ranger offers, and to configure and tune camera parameters to get high quality data for a specific task. Parameter setting can be saved for later usage in the real-time image analysis application. Note, that Ranger Studio is not a tool for automatic object analysis. For this, the Ranger has to be complemented with other software components.

In Ranger Studio the user can connect to one of, possibly, several Rangers connected. After establishing contact, the user can display both live 2D images, acquire collections of MultiScan data with display of each component individually, or acquire shape profiles for display as 3D images. Data can be visualized in several different ways with tools such as zooming, profile viewing, and interactive 3D-rendering. The purpose of the 2D image mode is to setup the measurement region and prepare the system for making 3D and MultiScan measurements.

Coordinator

The Coordinator is a software tool that guides the user through the complete calibration procedure. It assists the user in a workflow from the preparation steps, via the interactive calibration step with immediate feedback about the achieved calibration accuracy, to the final uploading of calibration results to the flash memory of the Ranger where it persists also after power-cycling. The calibration can be performed in a few minutes and after completion, the Ranger is ready to provide calibrated data to the vision application via the iCon API.



EASY 3D CALIBRATION

Ranger versions and accessories

The Ranger is available in three main models: Ranger C, Ranger E, and Ranger D. Each model is also offered in several variants with sensor resolution of 512 x 512 or 1 536 x 512 and with an additional high resolution line of 3 072 for gray scale measurements. Ranger C and Ranger E are also available with a high-pass IR-filter covering rows 100–512 of the sensor. The filter is useful to shield out ambient light or to separate MultiScan light sources from the 3D region of the sensor. All Rangers are delivered with a printed Quickstart guide that describes the hardware, basic functionality, and how to connect it and get started.

Accessories

The 3D Camera development software CD contains the configuration tool (Ranger Studio), the APIs required to integrate the Ranger with example code and documentation (SDK), and user-manuals. It should be noted that the CD comes with a lifetime development license.

As a service, most things to get started using the Ranger, such as power supply, power I/O terminal, cables, and

printed operating instructions, are gathered in an accessory kit. These items can also be ordered separately, as can a large range of cables of different lengths, laser, mounting parts, etc. It should be noted that some accessories are for use with either Ranger C or Ranger E/D, whereas others can be used with any Ranger model.

For safety reasons, in installations using a Ranger with a 3B class laser, it is required to have a key box with a removable key that can block the power to the laser unit. This is to ensure that the laser is not turned on by accident during service or maintenance. Such a box is offered as an accessory to Ranger.

For Ranger E/D when used with very long cabling distances, or in extreme EMC environments, an optical fiber solution with fiber cable and opto-adapters are offered. Moreover, for systems with several Ranger E/D units connected, a Gigabit Ethernet switch is available. By connecting each Ranger to the switch, there will only be a need for one cable to the hosting PC and only one Gigabit Ethernet board in the PC.

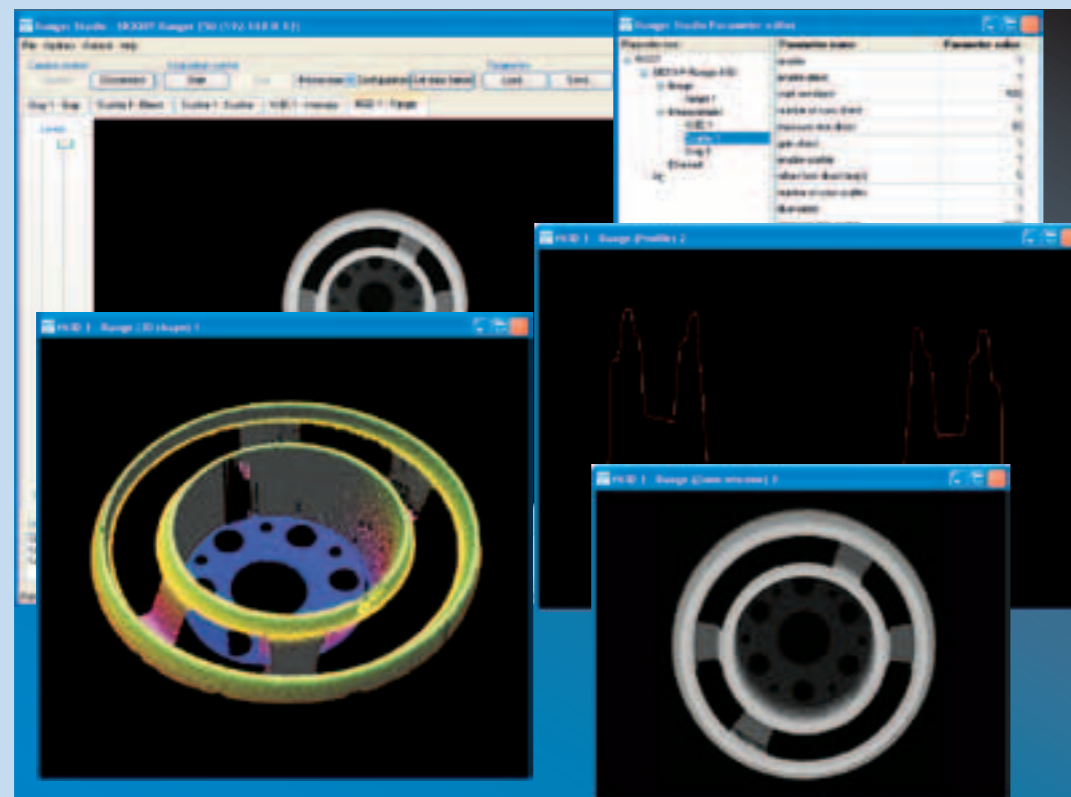

Ranger – the key to successful vision solutions!

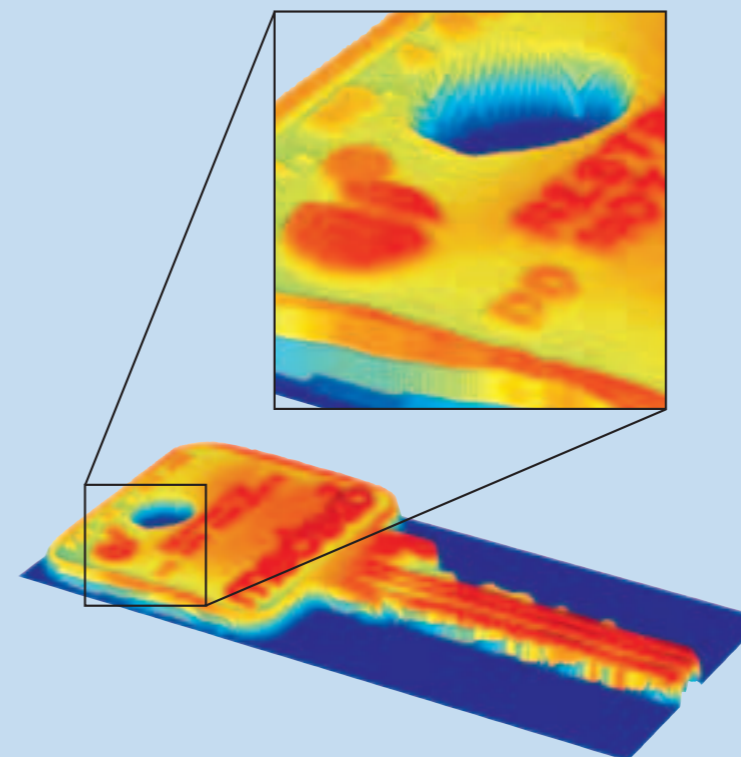

3D cameras: Ranger C

	Sensor Resolution
	1536 x 512
	512 x 512
3D cameras	

- The fastest 3D available!
- MultiScan technology
- Easy to integrate into existing CameraLink systems
- Flexible product for a wide range of applications
- Best market price/performance
- Flexible field of view thanks to free choice of lens and geometry

Dimensional drawings

Ranger C camera dimension, mid (mm)

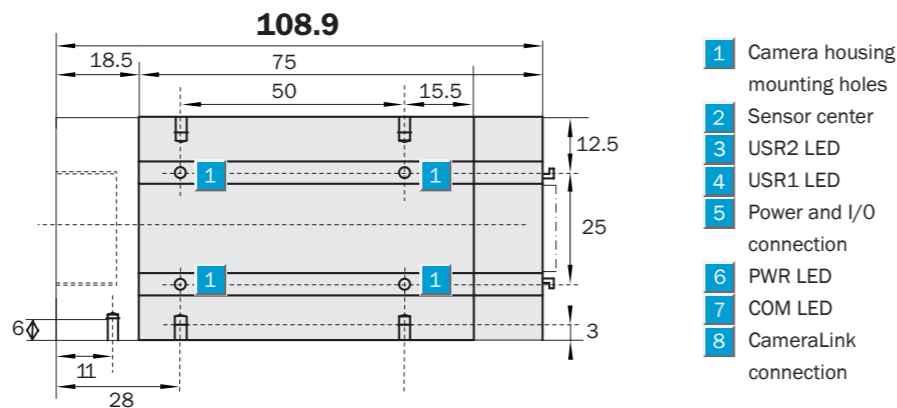

Ranger C camera dimension, front (mm)

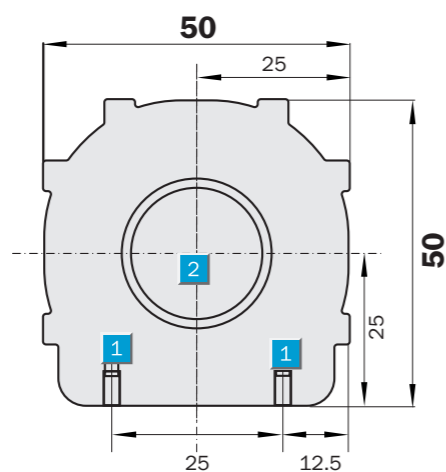

Connection type

Ranger C camera dimension, rear (mm)

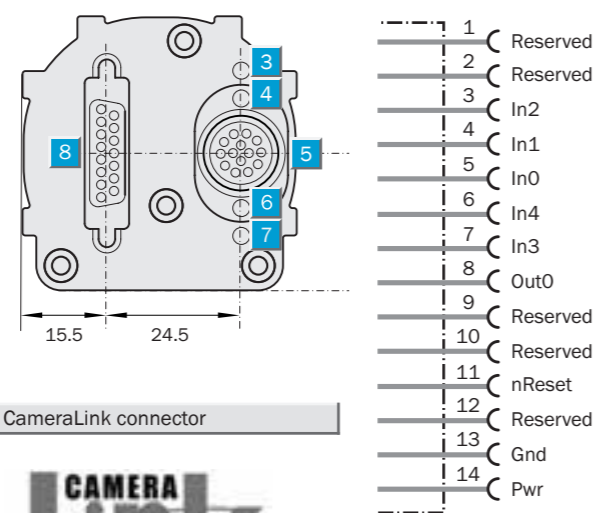

CameraLink connector



The CameraLink connector is specified in the CameraLink standard and is a 26-position high-density Mini D Ribbon (MDR) female plug.

CameraLink cable		Power and I/O	
Type	Order no.	Type	Order no.
3 m	1014310	3 m	1014266
10 m	1014311	10 m	1014324

Technical specifications

	Ranger C	40	50	50-IR	55	55-IR
Performance	Up to 30 000 3D profiles per second Up to 10 000 MultiScan blocks per second, each containing 3 features					
Communication interface ¹⁾	CameraLink					
Host platform ²⁾	PC, Windows XP					
Development environment	C++ (VS .NET 2003/2005) or C					
Synchronisation of data	Free running, light switch enable, rotary encoder trig					
Encoder interface	TTL levels					
Max. encoder frequency	2 MHz					
Digital inputs	5 x TTL					
Digital outputs	1 x TTL					
Power supply	12 ... 24 V DC					
Power consumption	8 W, 1.25 A					
Dimensions (L x H x D)	50 mm x 50 mm x 110 mm					
Weight	390 g					
Enclosure rating	IP 20					
Housing material	Aluminium, surface varnished					
Camera house temperature	5 ... 50 °C					
HiRes gray line resolution	3 072					
C-mount optics	1 inch ½ inch					
Imager	CMOS					
IR filter ³⁾	High-pass filter, cutoff at 750 nm					
Gray line resolution	1 536 512					
3D profile resolution	1 536 512					
Scatter resolution	1 536 512					
Maximum 3D height resolution	13 bits 1/16 pixel					

¹⁾ Frame Grabber requirements: 33/66 MHz, PCI 32bit@33MHz. Support for Com port mapping, 2 x 8 bit two-taps interleave data mode. Line-scan, true line-scan. Pixels/line: 512-64kB depending on application
²⁾ PC requirements: Min Pentium III, 1.5 GHz, 256 MB RAM, half-length PCI slot.
³⁾ For separation of multiple light sources. Row 100-511 with filter, Row 0-10 without filter

Diagrams

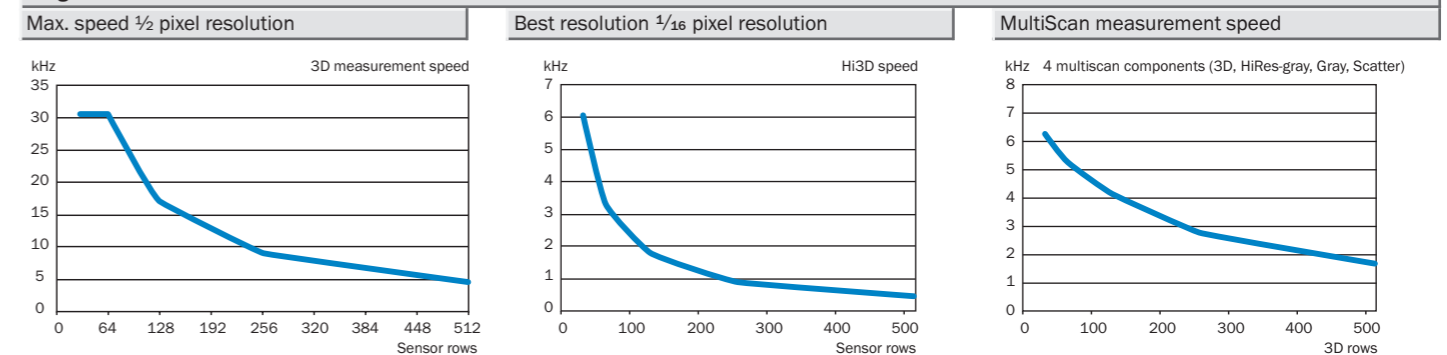

Ordering information

Accessories	Order no.	3D cameras	Order no.	Ranger C accessory kit (1014313)	Order no.
Ranger C accessory kit	1014313	Type		Ranger M/C power-I/O terminal	1014284
Ranger C development software	1014314	Ranger C40	1014218	Ranger power supply, 24 V DC	2040591
Ranger M/C power-I/O terminal	1014284	Ranger C50	1014216	Ranger CameraLink cable, 3 m	1014310
Ranger power supply, 24 V DC	2040591	Ranger C50-IR	1014223	SAH Power-I/O cable, 3 m	1014266
CameraLink frame grabber single board	6030530	Ranger C55	1014217	Lens, 25 mm, F1.4, 1"	1014252
Camera mounting parts	1014255	Ranger C55-IR	1014224	Camera mounting parts	1014255
Terminal box, ICT-B	1028342			Ranger C operating instructions	
Lens 25 mm, F1.4, 1"	1014252				
Laser triangulation parts	1014254				
Laser, 660 nm, 35 mW	6033005				

	Sensor Resolution
	1536 x 512
	512 x 512
3D cameras	

Dimensional drawing
Ranger E/D camera dimension, bottom (mm)

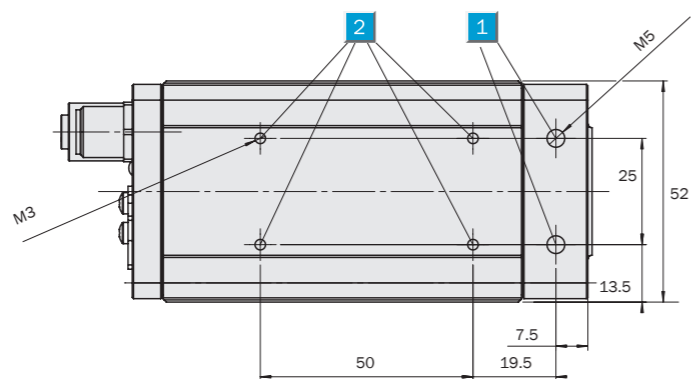

- 1** Mounting holes M5, 9 mm (2 x)
- 2** Mounting holes M3, 3 mm (4 x per side)
- 3** Power I/O connector (M12 male)
- 4** Encoder connector (M12 female)
- 5** Gigabit Ethernet connector (RJ 45)
- 6** LEDs:

Ranger E/D camera dimension, side (mm)

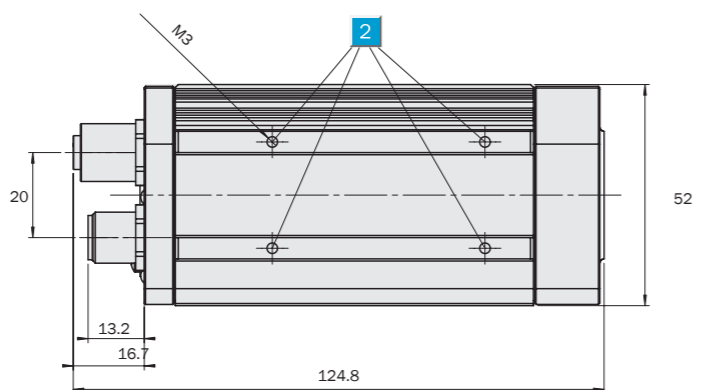

- On Supply voltage OK (green)
- Link Ethernet connected (green)
- Data Camera sends data (yellow)
- Function Reserved

Connection type
Ranger E/D camera dimension, rear (mm)

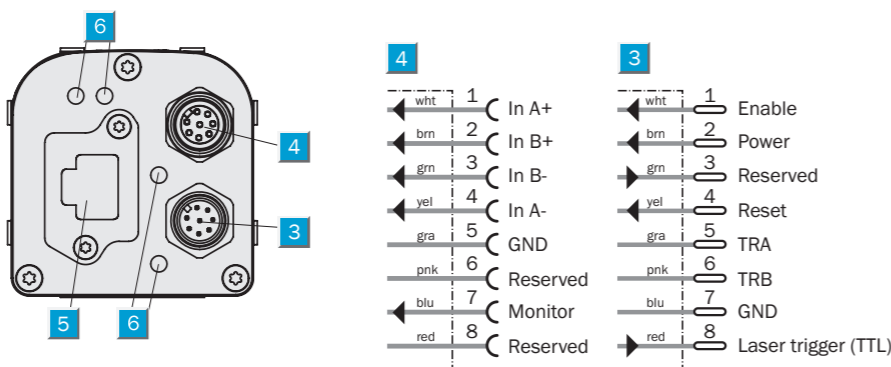

5 Pin configuration according to the Gigabit Ethernet standard defined by IEEE 802.3ab

Gigabit Ethernet cable, Cat. 6		Encoder cable open		Power I/O cable open	
Type	Order no.	Type	Order no.	Type	Order no.
5 m	6033029	2 m	6029330	2 m	6020633
10 m	6033030	5 m	6029331	5 m	6020993
20 m	6033031	10 m	6032324	10 m	6022152
70 m	6033032			15 m	6022153

Technical specifications	Ranger	E40	E50	E50-IR	E55	E55-IR	D40	D50				
Performance	Up to 35 000 3D profiles/s											
	Up to 1 000 3D profiles/s											
	MultiScan functionality											
Communication interface	Gigabit Ethernet											
Host platform ¹⁾	PC, Windows XP											
Development environment	C++ (VS.NET 2003/2005) or C											
Synchronisation of data	Free running, light switch enable, rotary encoder trig											
Encoder interface	RS422 (TTL levels)											
Max. encoder frequency	2 MHz											
Digital Inputs	4 x HIGH = 10 V ... 28.8 V											
Digital Outputs	1 x TTL											
	2 x B-type; <100 mA											
Power Supply	24 V DC											
Ripple	<5 Vpp											
Power consumption	7 W, 0.8 A											
Dimensions (L x H x D)	125 x 52 x 52 mm											
Weight	360 g											
Enclosure rating	IP 20											
Housing material	Aluminum, surface varnished											
	Connectors: nickel-plated brass											
Ambient temperature	Operation 0 ... +45 °C											
	Storage: -20 ... +70 °C											
Shock load	15 g, 3 x 6 directions											
Vibration load	5 g, 58 ... 150 Hz											
C-mount optics	1 inch											
	½ inch											
Imager	CMOS											
IR filter ²⁾	High-pass filter, cutoff at 750 nm											
HiRes gray line resolution	3 072											
Gray line resolution	1 536											
	512											
Scatter resolution	1 536											
	512											
3D profile resolution	1 536											
	512											
Maximum 3D height resolution	13 bits 1/16 pixel											

¹⁾ Recommended PC for Vision System: 3.0 GHz CPU, 800 MHz bus speed, 1024 MB RAM
²⁾ For separation of multiple light sources. Row 100-511 with filter. Row 0-10 without filter

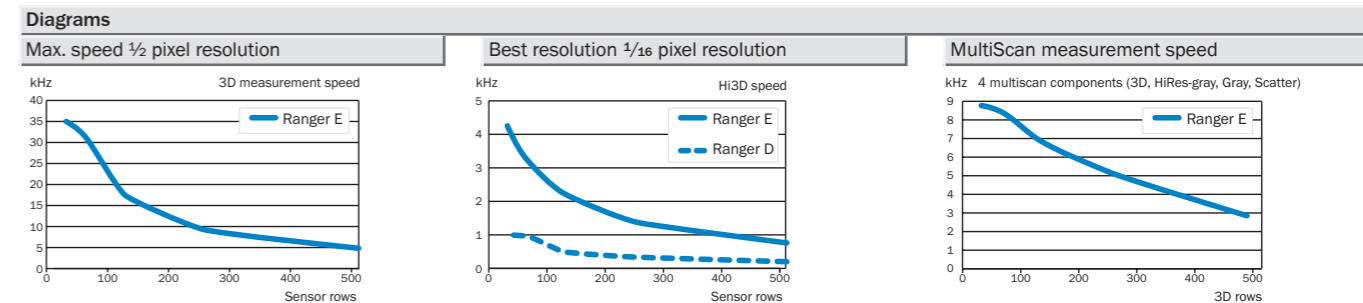

Ranger E/D accessories		Order no.	3D Cameras		Ranger E/D accessory kit (2040857)	Order no.
Ranger E/D accessory kit		2040857	Type	Order no.	Ranger E/D power-I/O terminal	6033171
Gigabit Ethernet board		6032329	Ranger E40	1040378	Ranger power supply, 24 V DC	2040591
Ranger E/D development SW on CD		2040603	Ranger E50	1040379	Ranger E/D Gigabit Ethernet cable, 5 m	6033029
Ranger E/D power-I/O terminal		6033171	Ranger E55	1040380	Ranger E/D PIO-encoder Y cable	6033172
Ranger E/D PIO-encoder Y cable		6033172	Ranger E50 IR	1040381	Lens, 25 mm, F1.4, 1"	1014252
Ranger power supply, 24 V DC		2040591	Ranger E55 IR	1040382	Camera mounting parts	1014255
Camera mounting parts		1014255	Ranger D40	1040383	Ranger E/D operating instructions	8011731
Lens, 25 mm, F1.4, 1"		1014252	Ranger D50	1040384		
Laser, 660 nm, 35 mW		6033005				
Laser triangulation parts		1014254				

Australia

Phone +61 3 9497 4100
1800 33 48 02 - tollfree
E-Mail sales@sick.com.au

Belgium/Luxembourg

Phone +32 (0)2 466 55 66
E-Mail info@sick.be

Brasil

Phone +55 11 3215-4900
E-Mail sac@sick.com.br

Ceská Republika

Phone +420 2 57 91 18 50
E-Mail sick@sick.cz

China

Phone +852-2763 6966
E-Mail ghk@sick.com.hk

Danmark

Phone +45 45 82 64 00
E-Mail sick@sick.dk

Deutschland

Phone +49 211 5301-280
E-Mail info@sick.de

España

Phone +34 93 480 31 00
E-Mail info@sick.es

France

Phone +33 1 64 62 35 00
E-Mail info@sick.fr

Great Britain

Phone +44 (0)1727 831121
E-Mail info@sick.co.uk

India

Phone +91-22-4033 8333
E-Mail info@sick-india.com

Israel

Phone +972-4-999-0590
E-Mail info@sick-sensors.com

Italia

Phone +39 02 27 43 41
E-Mail info@sick.it

Japan

Phone +81 (0)3 3358 1341
E-Mail support@sick.jp

Nederlands

Phone +31 (0)30 229 25 44
E-Mail info@sick.nl

Norge

Phone +47 67 81 50 00
E-Mail austefjord@sick.no

Österreich

Phone +43 (0)22 36 62 28 8-0
E-Mail office@sick.at

Polska

Phone +48 22 837 40 50
E-Mail info@sick.pl

Republic of Korea

Phone +82-2 786 6321/4
E-Mail kang@sickkorea.net

Republika Slovenija

Phone +386 (0)1-47 69 990
E-Mail office@sick.si

România

Phone +40 356 171 120
E-Mail office@sick.ro

Russia

Phone +7 495 775 05 34
E-Mail info@sick-automation.ru

Schweiz

Phone +41 41 619 29 39
E-Mail contact@sick.ch

Singapore

Phone +65 6744 3732
E-Mail admin@sicksgp.com.sg

Suomi

Phone +358-9-25 15 800
E-Mail sick@sick.fi

Sverige

Phone +46 10 110 10 00
E-Mail info@sick.se

Taiwan

Phone +886 2 2375-6288
E-Mail sales@sick.com.tw

Türkiye

Phone +90 216 587 74 00
E-Mail info@sick.com.tr

United Arab Emirates

Phone +971 4 8865 878
E-Mail info@sick.ae

USA/Canada/México

Phone +1(952) 941-6780
1 800-325-7425 - tollfree
E-Mail info@sickusa.com

More representatives and agencies
in all major industrial nations at
www.sick.com